

Optics Experiment 1 - The Law of Reflection

A few simple principles determine the shape and location of an image created by reflection in a mirror. One principle is light propagates in a straight line. The Law of Reflection states that for any reflected light ray the angle of incidence equals the angle of reflection. The purpose of this experiment is to study the reflection of a single ray of light and to empirically verify the law of reflection.

Equipment needed

- Optics bench
- Ray table and base
- Slit plate
- Ray optics mirror
- Light source
- Component holder
- Slit mask

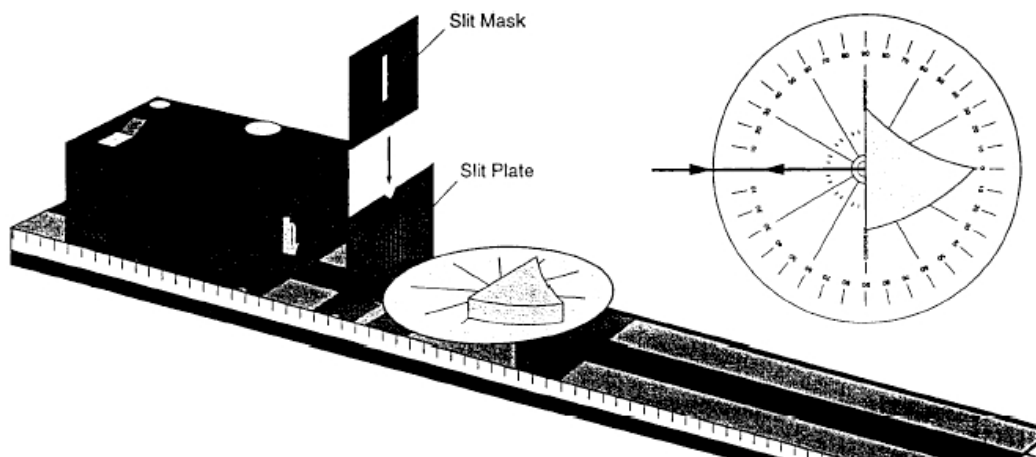

Figure 1 (Courtesy of PASCO)

Procedure

Set up the optics bench as shown in Fig. 1. Adjust the components of the optical system such that a single light ray is aligned with bold arrow labeled "normal" on the ray table degree scale. Align the flat edge of the side of the reflection surface with line labeled "component" on the ray table. If positioned correctly the bold "normal" line on the ray table will be normal to (or at a right angle to) the flat edge of the mirror. With the single ray shining on the normal line, rotate the ray table and watch the reflected ray. The angles of incidence and reflection are measured with respect to the normal line. See Fig. 2.

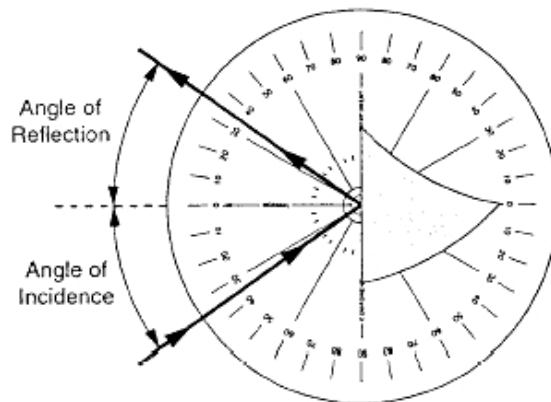

Figure 2 (Courtesy of PASCO)

Move the ray table to angles 0, 10, 20, 30, 40, 50, 60, 70, 80, and 90 degrees. For each angle of incidence record angles of reflection for angles of incidence on both sides of the normal line (two sets of data).

What relationship holds between the angle of incidence and the angle of reflection?

Can you state the pattern of your results in a single statement?

Questions

1. Are the results for the two measurements the same? Why or why not?
2. A second part of the law of reflection states the incident ray, the normal, and the reflected ray all lie in the same plane. Discuss how this is shown in your experiment.
3. You were asked to measure the angle of reflection when the ray was incident on either side of the normal line. What advantages does this provide?
4. Does the law of reflection apply to other natural phenomena other than light, e.g., sound, radio waves, etc?

Optics Experiment 2 - The Law of Refraction

In experiment 1 you saw how the direction of a light ray was abruptly changed by a reflective surface. The direction in which light travels is also changed when it crosses a boundary between two different transparent media such as air and acrylic or glass and water. This is known as refraction. In this experiment we will determine the relationship between incident and reflected rays upon crossing such an optical boundary and use this relationship to determine properties about transparent media.

The law of refraction or Snell's Law states:

$$n_1 \sin \theta_1 = n_2 \sin \theta_2$$

The quantities n_1 and n_2 are constants known as indices of refraction. An index of refraction is a characteristic of any transparent medium and varies with the material. The angles θ_1 and θ_2 are the angles that the ray deviates from the normal line to the boundary between the two media (see Fig. 3).

Air is normally considered to have a refractive index of 1.0. This means that the speed of light in air is the same as the speed of light in free space. Although this is not exactly true the difference in speed is relatively inconsequential for most purposes.

When a ray of light travels from air into any denser medium, such as glass or water, it slows down. The indices of refraction for most objects transparent to light are between 1.0 and 1.6. Note that the index of refraction for any material is never less than 1.0.

An examination of Snell's Law shows that for transmission of a light ray from air into some denser transparent substance the index of refraction of the denser substance may be computed by measuring the angles of incidence and refraction.

Equipment needed

- Optics bench
- Ray table and base
- Slit plate
- Cylindrical lens
- Light source
- Component holder
- Slit mask

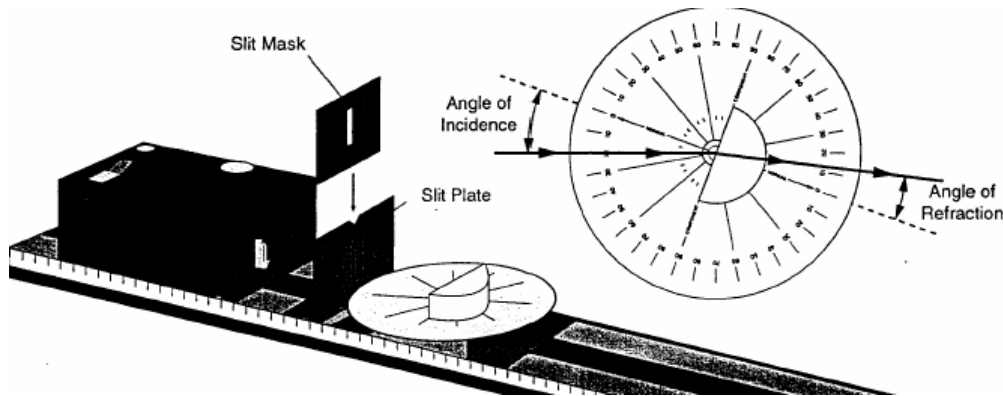

Figure 3 (Courtesy of PASCO)

Procedure

Set up the equipment as shown in Fig. 3. Adjust the components so that a single ray of light passes directly through the center of the ray table degree scale. Align the flat surface of the cylindrical lens on the line labeled "component". Proper alignment of the lens will place the radial lines perpendicular to the curved surface of the lens.

Without changing the alignment of the lens, take measurements for angles 0, 10, 20, 30, 40, 50, 60, 70, 80, and 90 degrees of incidence. Record the angles of refraction for each angle of incidence on both sides of the normal line (two sets of data) in the table below. Using your measured values complete the table below. Use Snell's law to calculate the value for n_2 . (Remember that the value for $n_1 = 1$).

Incident Angle (θ_i)	Refracted Angle (θ_r)		Average refracted angle	$\sin(\theta_i)$	$\sin(\theta_r)$	$n_2 = n_1 \sin(\theta_i) / \sin(\theta_r)$
	Right of Normal	Left of Normal				
0						
10						
20						
30						
40						
50						
60						
70						
80						
90						

Average value of $n_2 =$ _____
Standard deviation of $n_2.$ _____

Questions

1. Is the light ray bent when it passes into the lens perpendicular to the flat surface of the lens?
2. Is the ray bent when it passes out of the lens perpendicular to the curved surface of the lens?
3. Are the results for the two sets of measurements the same? Why or why not?
4. What is the index of refraction for the acrylic cylindrical lens?
5. In performing the experiment what, if any, difficulties did you encounter in measuring the angle of refraction for large angles of incidence?
6. Was all the light of the ray refracted? Was some reflected? In general some light is always reflected at an optical boundary even if the media are transparent.

7. Did the amount of reflected light vary with the angle of incidence? If so, how? What does this mean about the amount of transmitted light?

8. How does averaging the results of measurements taken with the incident ray striking from either side of the normal improve the accuracy of the results?

Optics Experiment 3 - Reversibility

In experiment 1 you determined what happens when a light ray encounters a reflective surface. In experiment 2 you determined what happens when light passes from air into a more optically dense medium. In this experiment we will determine what happens when a ray of light travels a reverse path through an optical system. In other words do the laws of reflection and refraction hold when light travels in the opposite direction or does the direction of the light beam even matter?

Equipment needed

- Optics bench
- Ray table and base
- Slit plate
- Cylindrical lens
- Light source
- Component holder
- Slit mask

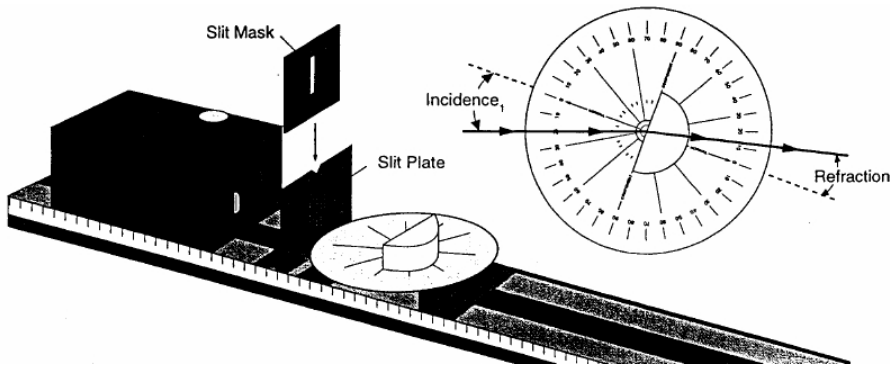

Figure 4 (Courtesy of PASCO)

Procedure

Set up the equipment as shown in Fig. 4. Adjust the components so a single ray of light passes directly through the center of the ray table degree scale. Align the flat surface of the cylindrical lens on the line labeled "component". Proper alignment of the lens will place the radial lines perpendicular to the curved surface of the lens.

Take measurements for angles 0, 10, 20, 30, 40, 50, 60, 70, 80, and 90 degrees of incidence and the corresponding angle of refraction. Record the angles of refraction for each angle of incidence on the flat surface of the lens. Now reverse the direction of light, so that it enters the curved surface first. Your incident angles will now be the refracted angles from before. Measure the new refracted rays and compare them to the previous values.

What relationship do you notice? This demonstrates the principle of reversibility.

Make a diagram showing a light ray passing into and out of the cylindrical lens. Show the correct angles of incidence and refraction at both surfaces (flat and curved). Use arrows to indicate the direction of propagation.

Questions

1. Using the second set of incidence and refraction angles, reconfirm the index of refraction for the acrylic lens. Assume that the index of refraction of air is 1.
2. Is the law of refraction the same for light rays going in either direction between the two media?
3. Does the principle of optical reversibility hold for reflection and refraction?